

"Your Connection"

**PA04 Series 1.00mm(.039") DIP LIF FFC/FPC Connectors**

- ⊙ Standard with Tube packing
- ⊙ Tin plated Phosphor Bronze Dual contacts
- ⊙ Insulation: Glass filled Nylon 6T UL 94V-0, Color Brown
- ⊙ Low insertion force
- ⊙ Engineering No's: CF09 Series

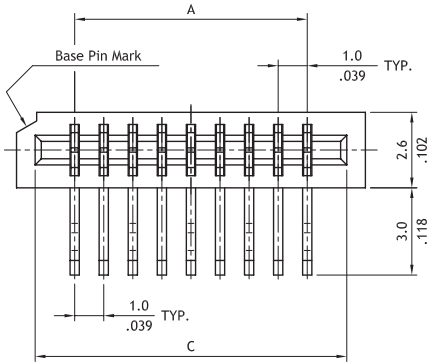

A = 1.00 \* No. of Spaces  
 B = A + 4.0  
 C = A + 2.3  
 \* Available in 4 through 32 circuits

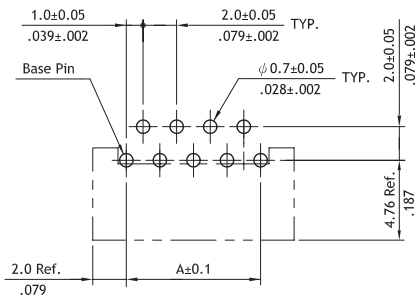
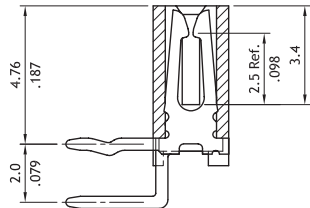
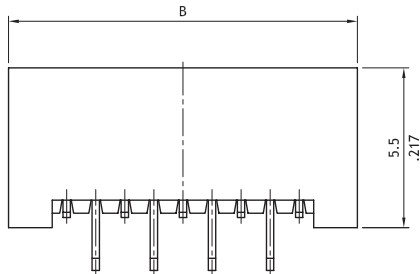

Recommended P.C. Board Layout

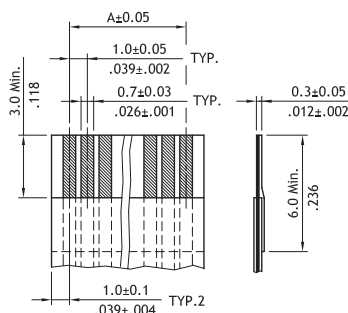

Accommodated FFC

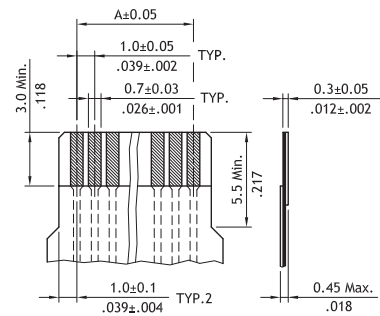

Accommodated FPC

**Ordering Code**

**1 PA04 2 32 3 1 4 H 5 2 6 00**

- ❶ Series No.
- ❷ Circuits : 04 to 32
- ❸ Plating code:  
1= Tin over Nickel

- ❹ Contact style:  
H= Right angle
- ❺ Color: 2= Brown

- ❻ Other options:  
00= Standard  
\* Special options Consult factory

**PA05 Series 1.00mm(.039") DIP ZIF FFC/FPC Connectors**

- ⊙ Standard with Tube packing
- ⊙ Tin plated contact with kinked tail
- ⊙ Insulation: Glass filled Nylon 6T UL 94V-0, Color Natural
- ⊙ Slider: Glass filled Nylon 6T UL 94V-0, Color Brown
- ⊙ Options: Upside contact or downside contact for right angle version; Straight DIP or SMT type
- ⊙ Engineering No's: CF10 Series

P/N PA05\*\*1U0T0

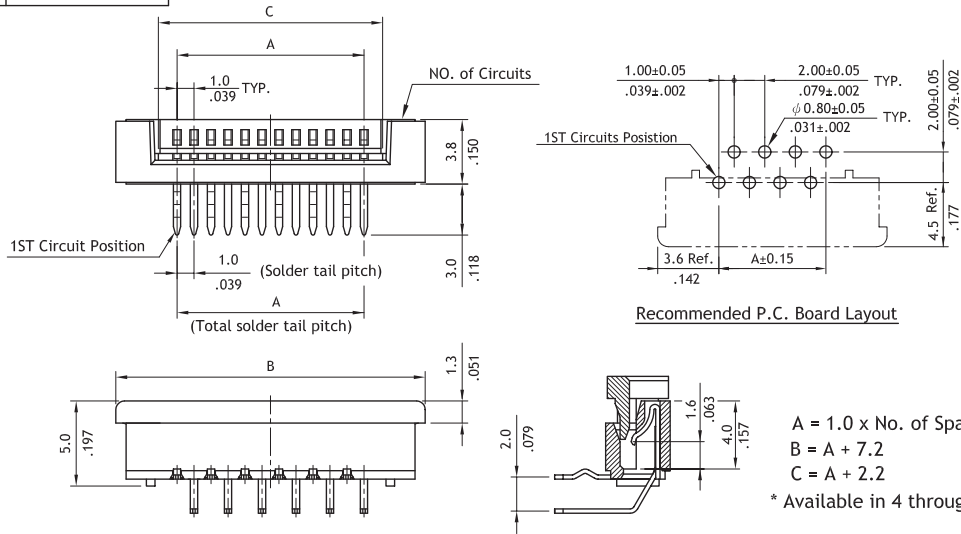

P/N PA05\*\*1D0T0

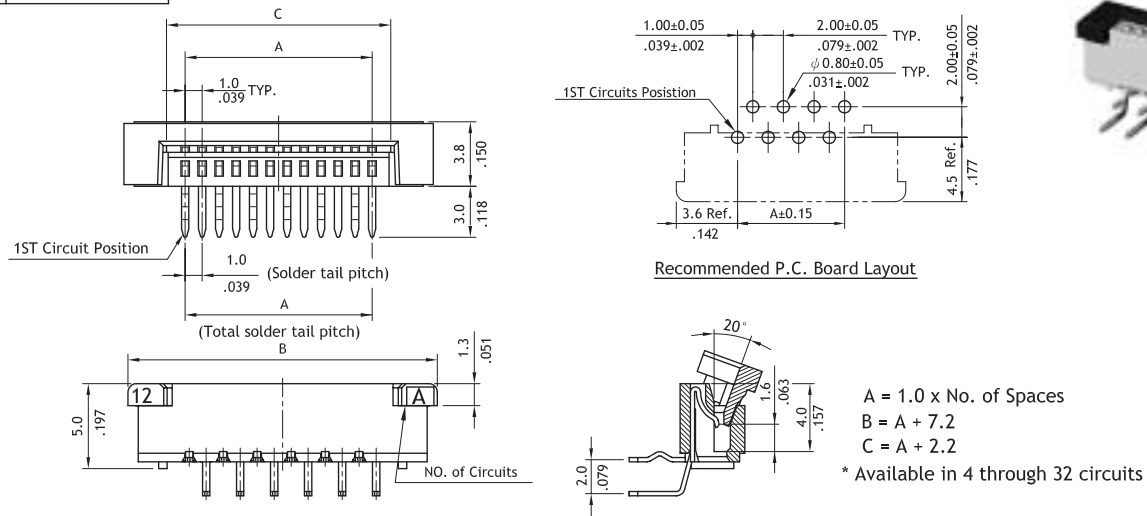

P/N PA05\*\*1V0T0

